



## AutoPack HS

Packaging machine



NL

- Automatische verpakings-machine voor enkele zakken.
- Deze High Speed (HS) uitvoering is de snelste in de markt.
- Geschikt voor zakken van net, jute en papier.
- Te combineren met alle weegmachines.
- Eenvoudige bediening via touchscreen.

DE

- Automatische Verpackungsmaschine für Einzelbeutel.
- Diese High Speed (HS) Version ist das schnellste auf dem Markt.
- Geeignet für Netz-, Jute- und Papiertüten.
- Zu kombinieren mit allen Arten Wiegenmaschinen.
- Einfache Bedienung über Berührungssensitiver Bildschirm.

EN

- Automatic packaging machine for single bags.
- This High Speed (HS) version is the fastest in the market.
- Suitable for net, jute and paper bags.
- Can be combined with all weighing machines.
- User friendly touchscreen.



# AutoPack HS

Packaging machine

| NL Specificaties:                                   | DE Spezifikationen:                           | EN Specifications:                     |   |
|---|---|--|---|
| Verpakkingsbereik:                                  | Verpackungsbereich:                           | Packing range:                         | <b>10 - 50 kg* (optional 5-50 kg)</b>                   |
| Zakbreedte  | Breite des Beutels:                           | Bag width:                             | <b>450 - 600 mm</b><br>(5kg option: 315 - 380 mm)       |
| Zakhoogte   | Höhe des Beutels:                             | Bag height:                            | <b>560 - 1100 mm</b>                                    |
| IP-beschermingsklasse                               | IP-Schutzklasse                               | IP-rating                              | <b>IP54</b>   |
| Capaciteit bij 25kg tot:                            | Leistung bei 25kg bis zu:                     | Capacity at 25kg up to:                | <b>20 bags/min*</b>                                     |
| Lucht consumptie:<br>(geconditioneerde droge lucht) | Luftverbrauch: (konditionierte trockene Luft) | Air consumption: (conditioned dry air) | <b>300 L/min</b>  |
| Voedingsspanning:                                   | Spannungsdaten:                               | Supply voltage                         | <b>3x 400V/50Hz+N+GND</b><br>(optional: 3x220v60Hz+GND) |
| Stroomverbruik:                                     | Anschlusswert:                                | Powerconsumption:                      | <b>10,5 kW</b>  |
| Gewicht van de machine:                             | Gewicht der Maschine:                         | Weight of the machine:                 | <b>2550 kg</b>  |

\* Afhankelijk van product.  
Abhängig von Produkt.  
Depends on product.

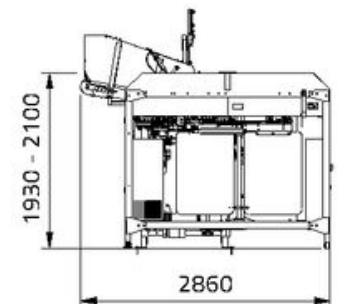
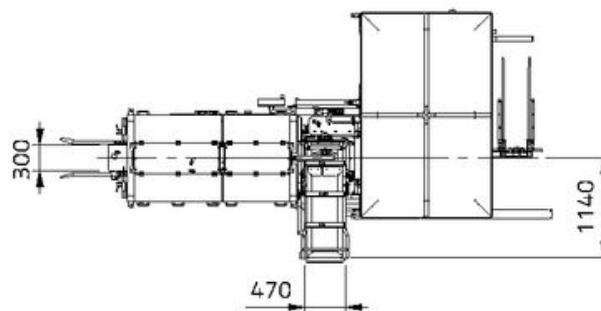
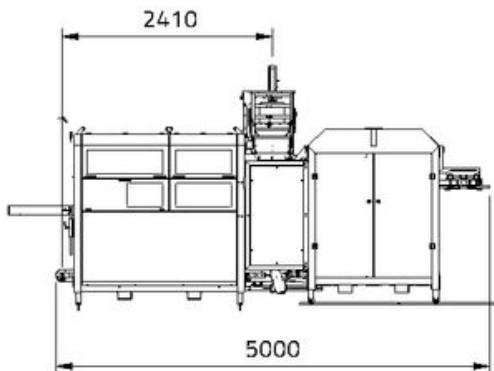

## Manter International B.V.

P.O. Box 2124 NL  
7801 CC Emmen  
The Netherlands

## Office

Phileas Foggstraat  
66 7825 AL Emmen  
The Netherlands

## Contact

+31 591 626300  
sales@manter.com  
www.manter.com

