

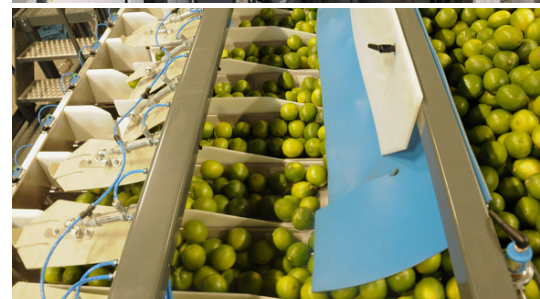

M10

Weighing machine



NL

- Weger met 10 weegschalen voor het wegen van verschillende producten.
- Optimale combinatie wordt gekozen uit de gevulde schalen, hierdoor nauwkeurig en snel.
- Verschillende afvoersystemen mogelijk.
- Te combineren met allerlei soorten verpakkingsmachines.
- Eenvoudige bediening middels touchscreen.

DE

- Waage mit 10 Behälter für das wiegen von verschiedene Produkte.
- Eine optimale Wahl wird errechnet aus die befüllte behälter, dadurch ist die Waage genau und schnell.
- Verschiedene Abtransportsysteme möglich.
- Zu kombinieren mit verschiedenen Verpackungsmaschinen.
- Einfache Bedienung mittels Touchscreen.

EN

- Weigher with 10 weighing buckets for weighing various products.
- By choosing an optimal combination from the filled buckets the machine has a high accuracy and speed.
- Various discharge systems possible.
- Combinations with many packaging machines possible.
- User-friendly touchscreen.



M10

Weighing machine

NL Specificaties:	DE Spezifikationen:	EN Specifications:	
Weegbereik:	Wiegebereich:	Weighing range:	0.25 - 12.5 kg*
Capaciteit bij 2.5kg tot:	Leistung bei 2.5kg bis zu:	Capacity at 2.5kg up to:	35 drops/min*
Inhoud weegbak:	Inhalt vom Behälter:	Capacity of the bucket:	6 ltr
IP-beschermingsklasse	IP-Schutzklasse	IP-rating	IP54
Lucht consumptie: (geconditioneerde droge lucht)	Luftverbrauch: (konditionierte trockene Luft)	Air consumption: (conditioned dry air)	125 L/min
Voedingsspanning:	Spannungsdaten:	Supply voltage	3x 400V/50Hz+N+GND
Stroomverbruik:	Anschlusswert:	Powerconsumption:	4.1 kW
Gewicht van de machine:	Gewicht der Maschine:	Weight of the machine:	1450 kg

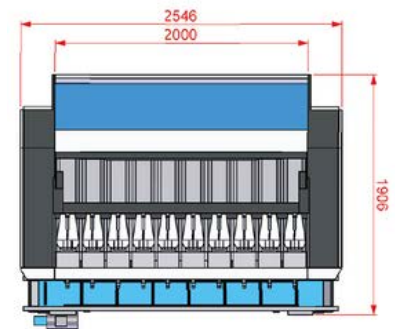
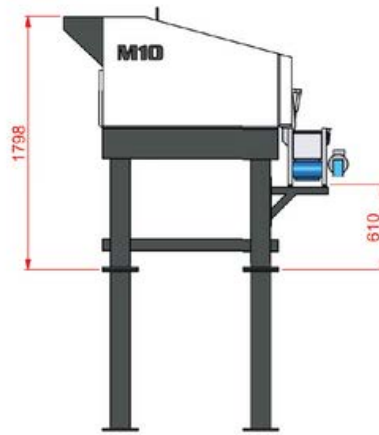
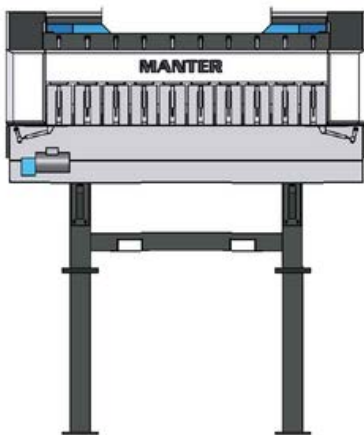

*Afhankelijk van product en afvoersysteem.
Abhängig von Produkt und Entladesystem.
Depends on product and discharge system.

Manter International B.V.

P.O. Box 2124 NL
7801 CC Emmen
The Netherlands

Office

Phileas Foggstraat
66 7825 AL Emmen
The Netherlands

Contact

+31 591 626300
sales@manter.com
www.manter.com

