

# M10i Ds

Weighing machine

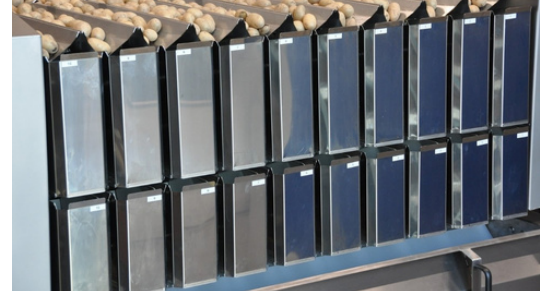

## NL

- Weger uitgevoerd in RVS met 10 weegschalen in lijn.
- Doseerbuckets boven weegbuckets.
- Optimaal voor hoge snelheid en kleine verpakkingen.
- Eenvoudige bediening middels touchscreen.
- Uitstekende reinigingsmogelijkheden door uitneembare componenten.
- Grote productvriendelijkheid vanwege geringe valhoogtes.

## DE

- Waage aus Va stahl mit 10 Wiegebehälter inl inie.
- Dosierbehälter über die Wiegebehälter.
- Optimal für hohe Geschwindigkeit und für Kleinpackung.
- Einfache Bedienung mittels Touchscreen.
- Hervorragende Reinigungsmöglichkeiten mittels abnehmbare Komponenten.
- Schonend für Produkte durch geringe Fallhöhen.

## EN

- Weigher in SST equipped with 10 weighing buckets inline.
- Dosing buckets above the weighing buckets.
- Optimised for high capacity runs with small weights.
- User-friendly touchscreen.
- Excellent cleaning possibilities thanks to removable components.
- High productfriendliness due to low drop heights.

# M10i Ds

Weighing machine

NL Specificaties:	DE Spezifikationen:	EN Specifications:	
Weegbereik:	Wiegebereich:	Weighing range:	<b>0.25 - 2.5 kg*</b>
Capaciteit bij 2.5kg tot:	Leistung bei 2.5kg bis zu:	Capacity at 2.5kg up to:	<b>50 drops/min*</b>
Inhoud weegbak:	Inhalt vom Behälter:	Capacity of the bucket:	<b>2.1 ltr</b>
IP-beschermingsklasse	IP-Schutzklasse	IP-rating	<b>IP54 or IP65</b>
Lucht consumptie: (geconditioneerde droge lucht)	Luftverbrauch: (konditionierte trockene Luft)	Air consumption: (conditioned dry air)	<b>125 L/min</b>
Voedingsspanning:	Spannungsdaten:	Supply voltage	<b>3x 400V/50Hz+N+GND</b>
Stroomverbruik:	Anschlusswert:	Powerconsumption:	<b>4.15 kW</b>
Gewicht van de machine:	Gewicht der Maschine:	Weight of the machine:	<b>1100 kg</b>

\* Afhankelijk van product en afvoersysteem. Abhängig von Produkt und Entladesystem. Depends on product and discharge system.

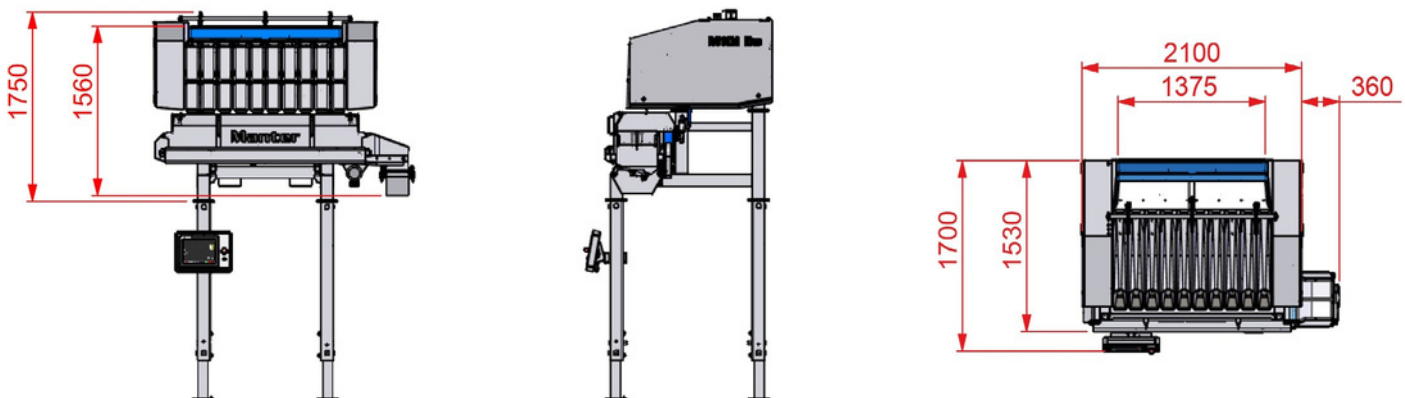

## Manter International B.V.

P.O. Box 2124 NL  
7801 CC Emmen  
The Netherlands

## Office

Phileas Foggstraat  
66 7825 AL Emmen  
The Netherlands

## Contact

+31 591 626300  
sales@manter.com  
www.manter.com

