



## M12 Ca

Weighing machine



### NL

- Weger met 12 lange weegschalen speciaal voor het wegen van lange producten zoals wortelen.
- Lange trilgoten met bewegend tussenschot om blokkeren door het product te vermijden.
- Verschillende afvoersystemen mogelijk.
- Te combineren met meerdere verpakkingsmachines.
- Eenvoudige bediening middels touchscreen.

### DE

- Waage mit 12 lange Behälter spezial für das wiegen von lange Produkte wie Karotten.
- Lange Vibrierrinnen mit bewegender zwischen panel um das blokkieren durch das produkt zu vermeiden.
- Verschiedene Abtransportsysteme möglich.
- Zu kombinieren mit verschiedenen Verpackungsmaschinen.
- Einfache Bedienung mittels Touchscreen.

### EN

- Weigher with 12 long weigh buckets specially built for long products like carrots and parsnips.
- Long vibrating lanes with moving panel in between to prevent blocking by the product.
- Various discharge systems possible.
- Combinations with many packaging machines possible.
- User-friendly touchscreen.

# M12 Ca

Weighing machine

NL Specificaties:	DE Spezifikationen:	EN Specifications:	
Weegbereik:	Wiegebereich:	Weighing range:	<b>0.25 - 5 kg*</b>
Capaciteit bij 2.5kg tot:	Leistung bei 2.5kg bis zu:	Capacity at 2.5kg up to:	<b>50 drops/min*</b>
Inhoud weegbak:	Inhalt vom Behälter:	Capacity of the bucket:	<b>8 ltr</b>
IP-beschermingsklasse	IP-Schutzklasse	IP-rating	<b>IP65</b>
Lucht consumptie: (geconditioneerde droge lucht)	Luftverbrauch: (konditionierte trockene Luft)	Air consumption: (conditioned dry air)	<b>150 L/min</b>
Voedingsspanning:	Spannungsdaten:	Supply voltage	<b>3x 400V/50Hz+N+GND</b>
Stroomverbruik:	Anschlusswert:	Powerconsumption:	<b>4.6 kW</b>
Gewicht van de machine:	Gewicht der Maschine:	Weight of the machine:	<b>1600 kg</b>

\* Afhankelijk van product en afvoersysteem.  
Abhängig von Produkt und Entladesystem.  
Depends on product and discharge system.

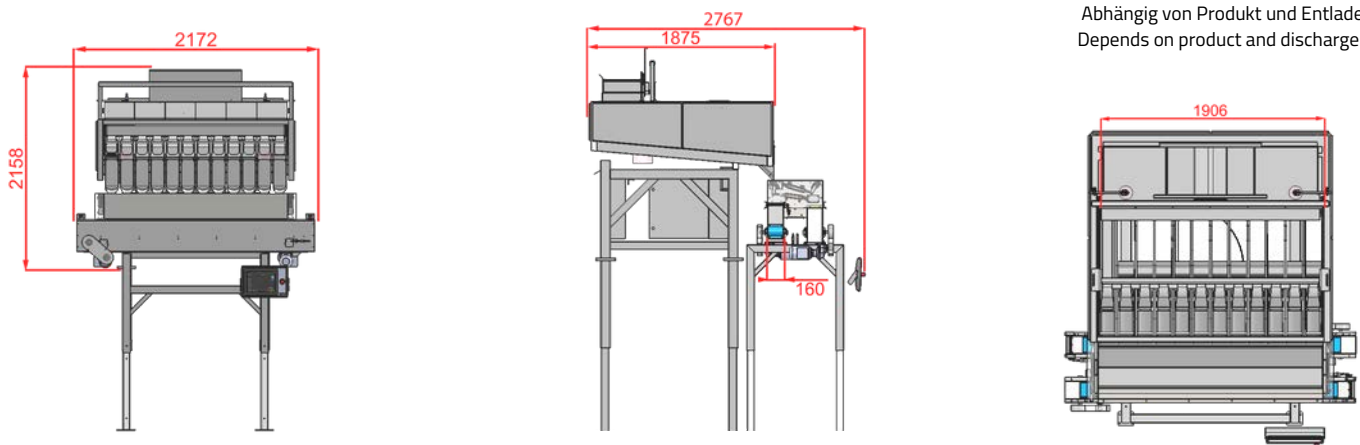

## Manter International B.V.

P.O. Box 2124 NL  
7801 CC Emmen  
The Netherlands

## Office

Phileas Foggstraat  
66 7825 AL Emmen  
The Netherlands

## Contact

+31 591 626300  
sales@manter.com  
www.manter.com

