



M12 V

Weighing machine



NL

- Weger met 12 V-vormige weegschalen die naar 2 zijden openen.
- Lage val, het gewicht wordt direct op de afvoerband gestort.
- Optimaal voor hoge snelheid met kleine gewichten.
- Verschillende afvoersystemen mogelijk.
- Te combineren met meerdere verpakkingsmachines.
- Eenvoudige bediening middels touchscreen.

DE

- Waage mit 12 V-Model Wiegebehälter die nach 2 Seiten öffnen.
- Niedrigen fall, da Gewicht wird direct auf den Abtransportband geladen.
- Optimal für hohe kapazität mit kleine gewichte.
- Verschiedene Abtransportsysteme möglich.
- Zu kombinieren mit verschiedenen Verpackungsmaschinen.
- Einfache Bedienung mittels Touchscreen.

EN

- Weigher with 12 V-shaped weighing buckets opening to 2 sides.
- Low drop, the weight will be dumped directly onto the discharge belt.
- Optimised for high capacity with small weights.
- Various discharge systems possible.
- Combinations with many packaging machines possible.
- User-friendly touchscreen.

M12 V

Weighing machine

NL Specificaties:	DE Spezifikationen:	EN Specifications:	
Weegbereik:	Wiegebereich:	Weighing range:	0.25 - 5 kg*
Capaciteit bij 2.5kg tot:	Leistung bei 2.5kg bis zu:	Capacity at 2.5kg up to:	50 drops/min*
Inhoud weegbak:	Inhalt vom Behälter:	Capacity of the bucket:	4.5 ltr
IP-beschermingsklasse	IP-Schutzklasse	IP-rating	IP54
Lucht consumptie: (geconditioneerde droge lucht)	Luftverbrauch: (konditionierte trockene Luft)	Air consumption: (conditioned dry air)	150 L/min
Voedingsspanning:	Spannungsdaten:	Supply voltage	3x 400V/50Hz+N+GND
Stroomverbruik:	Anschlusswert:	Powerconsumption:	4.6 kW
Gewicht van de machine:	Gewicht der Maschine:	Weight of the machine:	2000 kg

* Afhankelijk van product en afvoersysteem.
Abhängig von Produkt und Entladesystem.
Depends on product and discharge system.

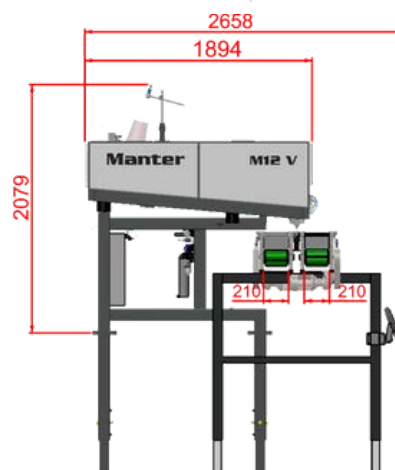

Manter International B.V.

P.O. Box 2124 NL
7801 CC Emmen
The Netherlands

Office

Phileas Foggstraat
66 7825 AL Emmen
The Netherlands

Contact

+31 591 626300
sales@manter.com
www.manter.com





M12 V

Weighing machine



EN

- Weigher with 12 V-shaped weighing buckets opening to 2 sides.
- Low drop, the weight will be dumped directly onto the discharge belt.
- Optimised for high capacity with small weights.
- Different discharge systems possible and to combine with all kinds of packing systems.
- User friendly touchscreen.

ES

- Pesadora con 12 en forma de V cubos de pesaje que se abren a 2 lados.
- Caída baja, el peso será arrojado directamente sobre el cinta de descarga.
- Optimizado para alta capacidad con pesos pequeños.
- Diferentes sistemas de descarga posible y combinar con todo tipo de sistemas de embalaje.
- Pantalla táctil fácil de usar.

FR

- Peseuse avec 12 en forme de V seaux de pesée ouvrant sur 2 côtés.
- Faible chute, le poids sera déversé directement sur le tapis de décharge.
- Optimisé pour une grande capacité avec de petits poids.
- Différents systèmes de décharge possible et à combiner avec toutes sortes de systèmes d'emballage.
- Écran tactile convivial.

M12 V

Weighing machine

EN Specificaties:	ES Especificaciones:	FR Specifications:	
Weighing range:	lage de pesée:	Plage de pesée:	0.25 - 5 kg*
Capacity at 1kg up to:	Capacité à 1kg à:	Capacité à 1kg à:	50 pcs/min*
Capacity of the bucket:	Contenu de la pesée:	Contenu de la pesée:	4.5 ltr
IP-rating	Classification IP:	Classification IP:	IP54
Air consumption: (conditioned dry air)	La consommation d'air: (L'air secher conditionnée)	La consommation d'air: (L'air secher conditionnée)	150 L/min
Supply voltage	La tension d'alimentation:	La tension d'alimentation:	3x 400V/50Hz+N+GND
Powerconsumption:	Consommation de l'électricité:	Consommation de l'électricité:	4.6 kW
Weight of the machine:	Poids de la machine:	Poids de la machine:	2000 kg

* Depends on product and discharge system.
Dépend du produit et du système de décharge.
Depende del producto y del sistema de descarga.

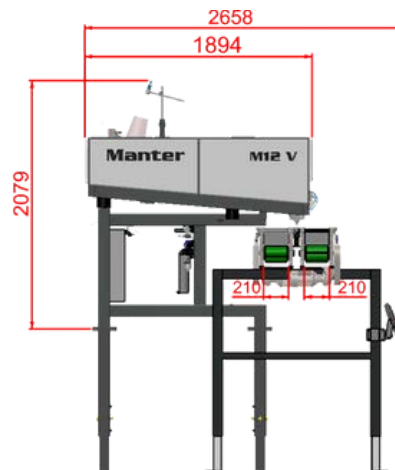

Manter International B.V.

P.O. Box 2124 NL
7801 CC Emmen
The Netherlands

Office

Phileas Foggstraat
66 7825 AL Emmen
The Netherlands

Contact

+31 591 626300
sales@manter.com
www.manter.com

