



M12i Fr

Weighing machine



NL

- Industriële weger voorzien van 16 weegschalen en 16 doseerbuckets, afneembaar en gemaakt van RVS.
- Voor het wegen van verse en diepgevroren voedsel zoals bevroren vis.
- Verschillende afvoersystemen mogelijk.
- Te combineren met meerdere verpakkingsmachines.
- Eenvoudige bediening middels touchscreen.

DE

- Industriewaage Ausgeführt mit 16 Weige behälter und 16 Dosierbehälter, abnehmbar aus Edelstahl.
- Zum Wiegen frischen und tiefgefrorenen Lebensmitteln und Non-Food-Produkte wie gefroren Fish.
- Verschiedene Abtransportsysteme möglich.
- Zu kombinieren mit verschiedenen Verpackungsmaschinen.
- Einfache Bedienung mittels Touchscreen.

EN

- Industrial weigher equipped with 16 weighing buckets and 16 dosing buckets, removable and made out of SST.
- For weighing fresh and deep-frozen food and non-food products such as frozen fish.
- Various discharge systems possible.
- Combinations with many packaging machines possible.
- User-friendly touchscreen.

M12i Fr

Weighing machine

NL Specificaties:	DE Spezifikationen:	EN Specifications:	
Weegbereik:	Wiegebereich:	Weighing range:	0.5 - 5 kg*
Capaciteit bij 1kg tot:	Leistung bei 1kg bis zu:	Capacity at 1kg up to:	50 drops/min*
Inhoud weegbak:	Inhalt vom Behälter:	Capacity of the bucket:	9 ltr
IP-beschermingsklasse	IP-Schutzklasse	IP-rating	IP65
Lucht consumptie: (geconditioneerde droge lucht)	Luftverbrauch: (konditionierte trockene Luft)	Air consumption: (conditioned dry air)	150 L/min
Voedingsspanning:	Spannungsdaten:	Supply voltage	3x 400V/50Hz+N+GND
Stroomverbruik:	Anschlusswert:	Powerconsumption:	5.5 kW
Gewicht van de machine:	Gewicht der Maschine:	Weight of the machine:	2450 kg

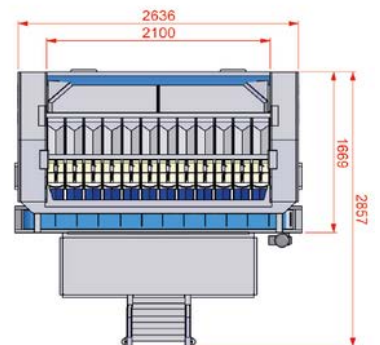
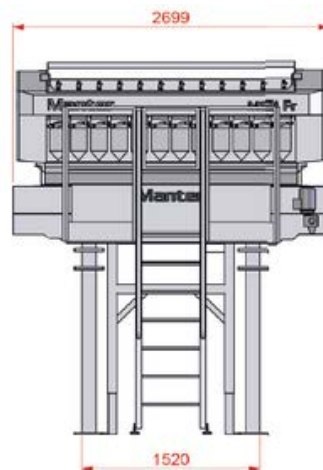
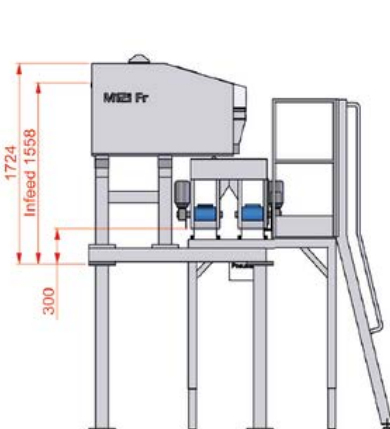

*Afhankelijk van product en afvoersysteem.
Abhängig von Produkt und Entladesystem.
Depends on product and discharge system.

Manter International B.V.

P.O. Box 2124 NL
7801 CC Emmen
The Netherlands

Office

Phileas Foggstraat
66 7825 AL Emmen
The Netherlands

Contact

+31 591 626300
sales@manter.com
www.manter.com

