



M12i V

Weighing machine



NL

- Industriële weger voorzien van 12 weegschalen en 12 doseerbuckets, gemaakt van roestvrij staal.
- Voor het wegen van verse en diepgevroren food en non-food producten.
- Verschillende afvoersystemen mogelijk.
- Te combineren met allerlei soorten verpakkingsmachines.
- Eenvoudige bediening middels touchscreen.

DE

- Industriewaage Ausgeführt mit 12 Wiege behälter und 12 Dosierbehälter, aus Edelstahl.
- Zum Wiegen frischen und tiefgefrorenen Lebensmittel und Non-Food-Produkte.
- Verschiedene Abtransportsysteme möglich.
- Zu kombinieren mit verschiedenen Verpackungsmaschinen.
- Einfache Bedienung mittels Touchscreen.

EN

- Industrial weigher equipped with 12 weighing buckets and 12 dosing buckets, made of stainless steel.
- For weighing fresh and deep-frozen food and nonfood products.
- Various discharge systems possible.
- Combinations with many packaging machines possible.
- User-friendly touchscreen.

M12i V

Weighing machine

NL Specificaties:	DE Spezifikationen:	EN Specifications:	
Weegbereik:	Wiegebereich:	Weighing range:	0.25 - 5 kg*
Capaciteit bij 1kg tot:	Leistung bei 1kg bis zu:	Capacity at 1kg up to:	60 drops/min*
Inhoud weegbak:	Inhalt vom Behälter:	Capacity of the bucket:	3.2 ltr
IP-beschermingsklasse	IP-Schutzklasse	IP-rating	IP54 or IP65
Lucht consumptie: (geconditioneerde droge lucht)	Luftverbrauch: (konditionierte trockene Luft)	Air consumption: (conditioned dry air)	150 L/min
Voedingsspanning:	Spannungsdaten:	Supply voltage	3x 400V/50Hz+N+GND
Stroomverbruik:	Anschlusswert:	Powerconsumption:	4.6 kW
Gewicht van de machine:	Gewicht der Maschine:	Weight of the machine:	1450 kg

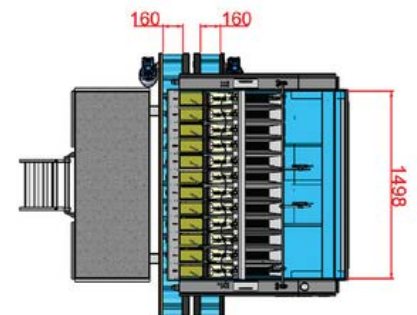
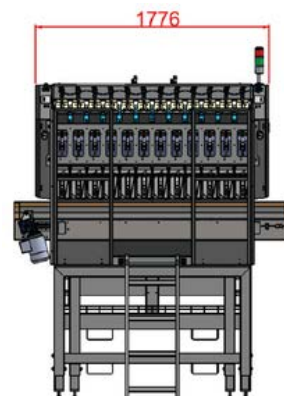
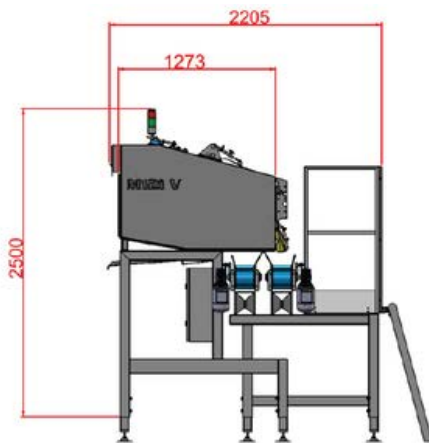

*Afhankelijk van product en afvoersysteem.
Abhängig von Produkt und Entladesystem.
Depends on product and discharge system.

Manter International B.V.

P.O. Box 2124 NL
7801 CC Emmen
The Netherlands

Office

Phileas Foggstraat
66 7825 AL Emmen
The Netherlands

Contact

+31 591 626300
sales@manter.com
www.manter.com

