

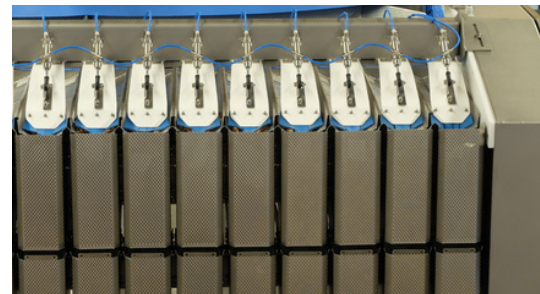

## M16i Fr

Weighing machine



### NL

- Industriële weger voorzien van 16 weegschalen en 16 doseerbuckets, afneembaar en gemaakt van RVS.
- Voor het wegen van verse en diepgevroren voedsel zoals bevroren vis.
- Verschillende afvoersystemen mogelijk.
- Te combineren met allerlei soorten verpakkingsmachines.
- Eenvoudige bediening middels touchscreen.

### DE

- Industriewaage Ausgeführt mit 16 Weige behälter und 16 Dosierbehälter, abnehmbar aus Edelstahl.
- Zum Wiegen frischen und tiefgefrorenen Lebensmitteln und Non-Food-Produkte wie gefroren Fish.
- Verschiedene Abtransportsysteme möglich.
- Zu kombinieren mit verschiedenen Verpackungsmaschinen.
- Einfache Bedienung mittels Touchscreen.

### EN

- Industrial weigher equipped with 16 weighing buckets and 16 dosing buckets, removable and made out of SST.
- For weighing fresh and deep-frozen food and non-food products such as frozen fish.
- Various discharge systems possible.
- Combinations with many packaging machines possible.
- User-friendly touchscreen.

# M16i Fr

Weighing machine

NL Specificaties:	DE Spezifikationen:	EN Specifications:	
Weegbereik:	Wiegebereich:	Weighing range:	<b>0.25 - 5 kg*</b>
Capaciteit bij 1kg tot:	Leistung bei 1kg bis zu:	Capacity at 1kg up to:	<b>80 drops/min*</b>
Inhoud weegbak:	Inhalt vom Behälter:	Capacity of the bucket:	<b>6 ltr</b>
IP-beschermingsklasse	IP-Schutzklasse	IP-rating	<b>IP65</b>
Lucht consumptie: (geconditioneerde droge lucht)	Luftverbrauch: (konditionierte trockene Luft)	Air consumption: (conditioned dry air)	<b>150 L/min</b>
Voedingsspanning:	Spannungsdaten:	Supply voltage	<b>3x 400V/50Hz+N+GND</b>
Stroomverbruik:	Anschlusswert:	Powerconsumption:	<b>5.5 kW</b>
Gewicht van de machine:	Gewicht der Maschine:	Weight of the machine:	<b>2700 kg</b>

\*Afhankelijk van product en afvoersysteem.  
Abhängig von Produkt und Entladesystem.  
Depends on product and discharge system.

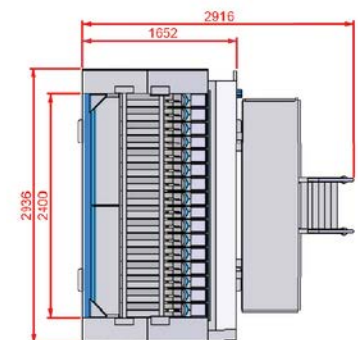
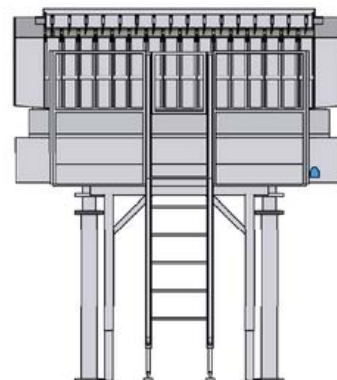
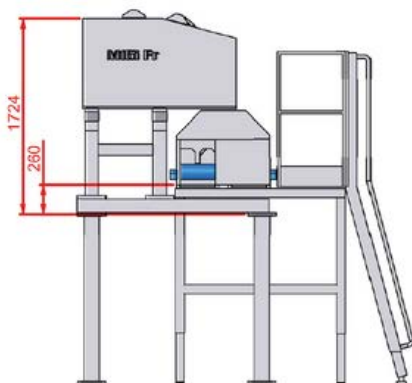

## Manter International B.V.

P.O. Box 2124 NL  
7801 CC Emmen  
The Netherlands

## Office

Phileas Foggstraat  
66 7825 AL Emmen  
The Netherlands

## Contact

+31 591 626300  
sales@manter.com  
www.manter.com

