



## M16i V

Weighing machine



### NL

- Combinatieweiger met 16 weegschalen voor hoge nauwkeurigheid.
- Hoge snelheid door de doseerbuckets boven de weegbuckets.
- Minimale valhoogte door v-vormige weegbakken.
- Eenvoudig schoon maken door uitneembare doseerbakken.
- Touchscreen bediening.
- Te combineren met allerlei soorten verpakkingsmachines.

### DE

- Kombinationswaage mit 16 Wiegebehälter für hohe Genauigkeit.
- Höhe leistung mit Dosierbehälter über die Wiegenbehälter.
- Minimale Fallhöhe mit V-Form Wiegenbehälter.
- Einfache Reinigung durch entfernbare Dosierbehälter.
- Touchscreen Bedienung.
- Zu kombinieren mit verschiedenen Verpackungsmaschinen.

### EN

- Combination weigher with 16 weighing scales for high accuracy.
- High speed due to the dosing buckets above the weighing buckets.
- Minimal falling height by v-shaped weighing buckets.
- Easy cleaning by detachable dosing buckets
- Touchscreen operation.
- Combinations with many packaging machines possible.

# M16i V

Weighing machine

NL Specificaties:	DE Spezifikationen:	EN Specifications:	
Weegbereik:	Wiegebereich:	Weighing range:	<b>0.5 - 5 kg*</b>
Capaciteit bij 1kg tot:	Leistung bei 1kg bis zu:	Capacity at 1kg up to:	<b>80 drops/min*</b>
Inhoud weegbak:	Inhalt vom Behälter:	Capacity of the bucket:	<b>3.8 ltr</b>
IP-beschermingsklasse	IP-Schutzklasse	IP-rating	<b>IP54 or IP65</b>
Lucht consumptie: (geconditioneerde droge lucht)	Luftverbrauch: (konditionierte trockene Luft)	Air consumption: (conditioned dry air)	<b>150 L/min</b>
Voedingsspanning:	Spannungsdaten:	Supply voltage	<b>3x 400V/50Hz+N+GND</b>
Stroomverbruik:	Anschlusswert:	Powerconsumption:	<b>5.5 kW</b>
Gewicht van de machine:	Gewicht der Maschine:	Weight of the machine:	<b>2450 kg</b>

\*Afhankelijk van product en afvoersysteem.  
Abhängig von Produkt und Entladesystem.  
Depends on product and discharge system.

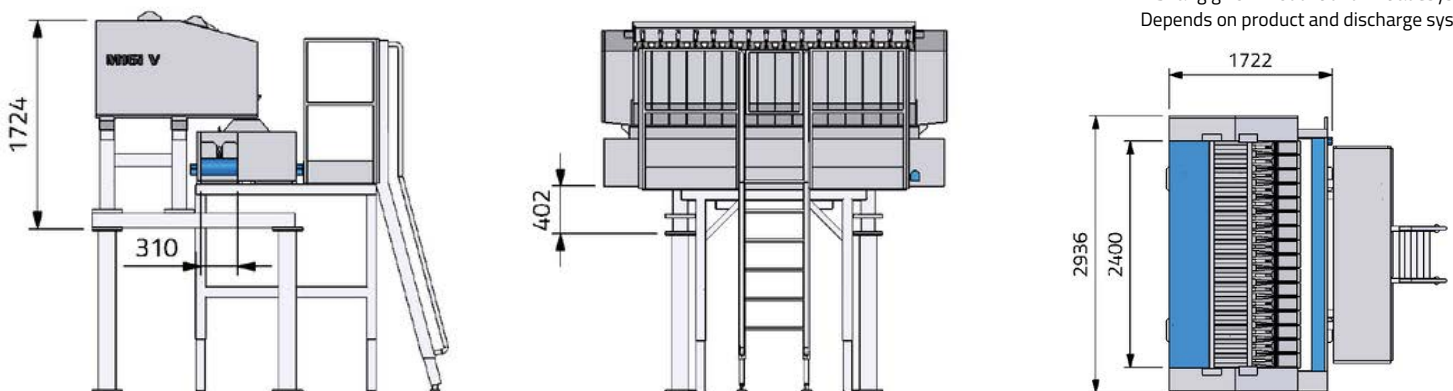

## Manter International B.V.

P.O. Box 2124 NL  
7801 CC Emmen  
The Netherlands

## Office

Phileas Foggstraat  
66 7825 AL Emmen  
The Netherlands

## Contact

+31 591 626300  
sales@manter.com  
www.manter.com

