



M2 XXL

Weighing machine



NL

- Lineaire weger uitgevoerd met 2 grote weegbakken, voor gewichten tussen 5 - 50kg.
- Snelheden tot 14 stortingen/ minuut bij 25kg.
- Iedere weegbak voorzien van drie trilgoten.
- Verschillende afvoersystemen mogelijk.
- Te combineren met allerlei soorten verpakkingsmachines.
- Eenvoudige bediening middels touchscreen.

DE

- Lineare Waage mit 2 großen Wiegebehältern für Gewichte 5-50kg.
- Kapazität bis zu 14 Gewichte/Minute bei 25kg.
- Jeder Wiegebehälter ist mit drei Vibrationsrinnen ausgestattet.
- Verschiedene Abtransportsysteme möglich.
- Zu kombinieren mit verschiedenen Verpackungsmaschinen.
- Einfache Bedienung mittels Touchscreen.

EN

- Linear weigher equipped with 2 large weighing buckets, for weights between 5 - 50kg.
- Capacity up to 14 drops/minute at 25kg.
- Each weighing bucket equipped with three vibrating lanes.
- Various discharge systems possible.
- Combinations with many packaging machines possible.
- User-friendly touchscreen.



M2 XXL

Weighing machine

NL Specificaties:	DE Spezifikationen:	EN Specifications:	
Weegbereik:	Wiegebereich:	Weighing range:	5 - 25 kg*
Capaciteit bij 25kg tot:	Leistung bei 25kg bis zu:	Capacity at 25kg up to:	14 drops/min*
Inhoud weegbak:	Inhalt vom Behälter:	Capacity of the bucket:	46 ltr
IP-beschermingsklasse	IP-Schutzklasse	IP-rating	IP54
Lucht consumptie: (geconditioneerde droge lucht)	Luftverbrauch: (konditionierte trockene Luft)	Air consumption: (conditioned dry air)	100 L/min
Voedingsspanning:	Spannungsdaten:	Supply voltage	3x 400V/50Hz+N+GND
Stroomverbruik:	Anschlusswert:	Powerconsumption:	3.6 kW
Gewicht van de machine:	Gewicht der Maschine:	Weight of the machine:	1050 kg

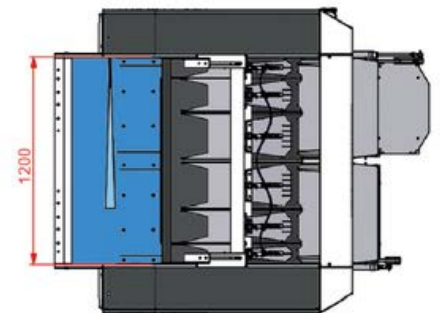
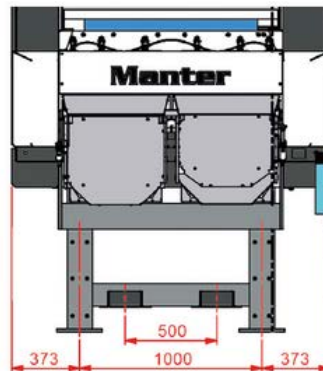
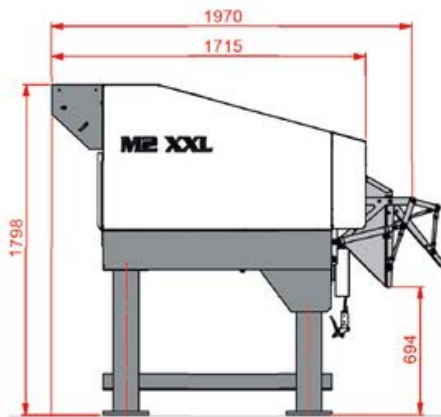

*Afhankelijk van product en afvoersysteem.
Abhängig von Produkt und Entladesystem.
Depends on product and discharge system.

Manter International B.V.

P.O. Box 2124 NL
7801 CC Emmen
The Netherlands

Office

Phileas Foggstraat
66 7825 AL Emmen
The Netherlands

Contact

+31 591 626300
sales@manter.com
www.manter.com

