

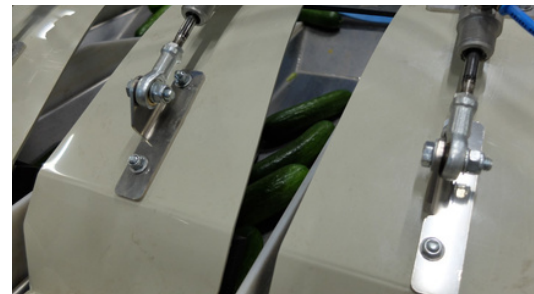

## M8

### Weighing machine



#### NL

- Weger met 8 weegschalen voor het wegen van verschillende producten.
- Optimale combinatie wordt gekozen uit de gevulde schalen, hierdoor nauwkeurig en snel.
- Verschillende afvoersystemen mogelijk.
- Te combineren met allerlei soorten verpakkingsmachines.
- Eenvoudige bediening middels touchscreen.

#### DE

- Waage mit 8 Wiegebehälter für das wiegen von verschiedene Produkte.
- Eine optimale wahl wird errechnet aus die befüllte behälter, dadurch is die Waage genau und schnell.
- Verschiedene Abtransportsysteme möglich.
- Zu kombinieren mit verschiedenen Verpackungsmaschinen.
- Einfache Bedienung mittels Touchscreen.

#### EN

- Weigher with 8 weighing buckets for weighing various products.
- By choosing an optimal combination out of the filled buckets, the weigher has an high accuracy and speed.
- Different discharge systems possible.
- Combinations with many packaging machines possible.
- User-friendly touchscreen.



## M8

Weighing machine

NL Specificaties:	DE Spezifikationen:	EN Specifications:	
Weegbereik:	Wiegebereich:	Weighing range:	<b>0.25 - 10 kg*</b>
Capaciteit bij 2.5kg tot:	Leistung bei 2.5kg bis zu:	Capacity at 2.5kg up to:	<b>35 drops/min*</b>
Inhoud weegbak:	Inhalt vom Behälter:	Capacity of the bucket:	<b>6 ltr</b>
IP-beschermingsklasse	IP-Schutzklasse	IP-rating	<b>IP54</b>
Lucht consumptie: (geconditioneerde droge lucht)	Luftverbrauch: (konditionierte trockene Luft)	Air consumption: (conditioned dry air)	<b>100 L/min</b>
Voedingsspanning:	Spannungsdaten:	Supply voltage	<b>3x 400V/50Hz+N+GND</b>
Stroomverbruik:	Anschlusswert:	Powerconsumption:	<b>3.4 kW</b>
Gewicht van de machine:	Gewicht der Maschine:	Weight of the machine:	<b>1250 kg</b>

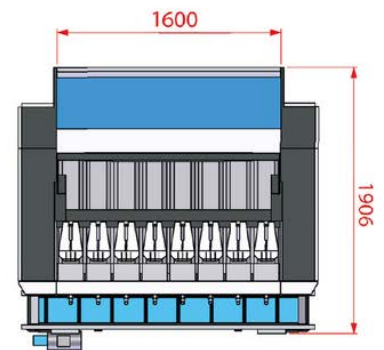
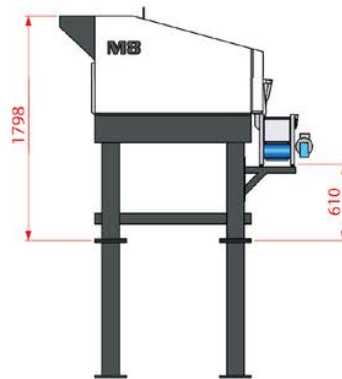
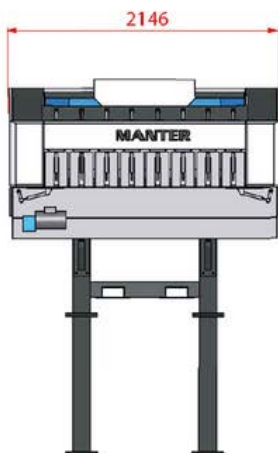

\*Afhankelijk van product en afvoersysteem.  
Abhängig von Produkt und Entladesystem.  
Depends on product and discharge system.

### Manter International B.V.

P.O. Box 2124 NL  
7801 CC Emmen  
The Netherlands

### Office

Phileas Foggstraat  
66 7825 AL Emmen  
The Netherlands

### Contact

+31 591 626300  
sales@manter.com  
www.manter.com

