



MD10 XL

Weighing machine



NL

- Weger met 10 XL weegschalen in 2 rijen van 5 tegenover elkaar.
- Leverbaar met banden in plaats van trilgoten.
- Verschillende afvoersystemen mogelijk.
- Te combineren met allerlei soorten verpakkingsmachines.
- Eenvoudige bediening middels touchscreen.

DE

- Waage ausgeführt mit grösse Wiegebehälter.
- Ausführbar mit bänder statt Vibrierrinnen.
- Verschiedene Abtransportsysteme möglich.
- Zu kombinieren mit verschiedenen Verpackungsmaschinen.
- Einfache Bedienung mittels Touchscreen.

EN

- Weigher with 10 weighing buckets in 2 rows of 5 opposite of each other.
- Can be delivered with feeding belts instead of vibrating lanes.
- Various discharge systems possible.
- Combinations with many packaging machines possible.
- User-friendly touchscreen.

MD10 XL

Weighing machine

| NL Specificaties: | DE Spezifikationen: | EN Specifications: | |
|---|--|---|---------------------------|
| Weegbereik: | Wiegebereich: | Weighing range: | 5 - 25 kg* |
| Capaciteit bij 25kg tot: | Leistung bei 25kg bis zu: | Capacity at 25kg up to: | 16 drops/min* |
| Inhoud weegbak: | Inhalt vom Behälter: | Capacity of the bucket: | 12 ltr |
| IP-beschermingsklasse | IP-Schutzklasse | IP-rating | IP54 |
| Lucht consumptie: (geconditioneerde droge lucht) | Luftverbrauch: (konditionierte trockene Luft) | Air consumption: (conditioned dry air) | 125 L/min |
| Voedingsspanning: | Spannungsdaten: | Supply voltage | 3x 400V/50Hz+N+GND |
| Stroomverbruik: | Anschlusswert: | Powerconsumption: | 4.9 kW |
| Gewicht van de machine: | Gewicht der Maschine: | Weight of the machine: | 2050 kg |

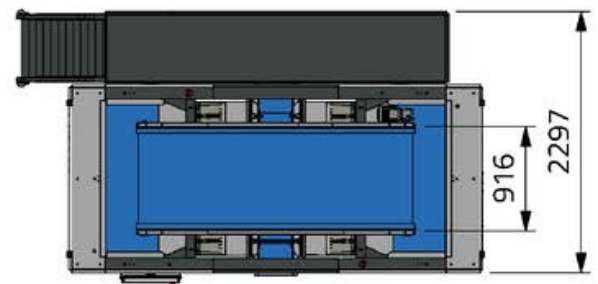
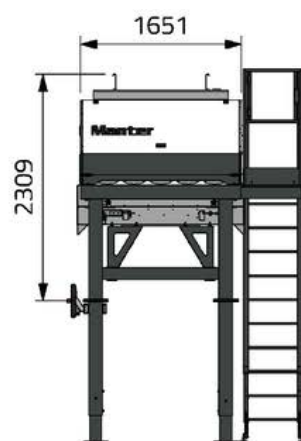
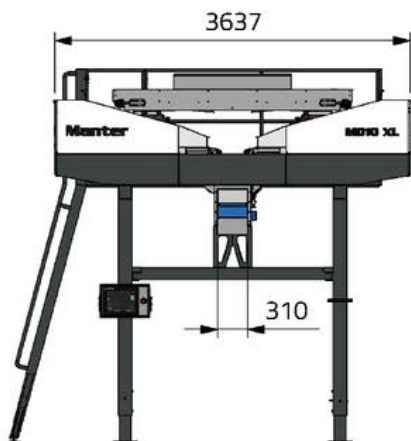

*Afhankelijk van product en afvoersysteem.
Abhängig von Produkt und Entladesystem.
Depends on product and discharge system.

Manter International B.V.

P.O. Box 2124 NL
7801 CC Emmen
The Netherlands

Office

Phileas Foggstraat
66 7825 AL Emmen
The Netherlands

Contact

+31 591 626300
sales@manter.com
www.manter.com

