



MD12

Weighing machine



NL

- Weger met 12 weegschalen in 2 rijen van 6 tegenover elkaar.
 - Optimaal voor hoge snelheid bij kleine verpakking.
 - Verschillende afvoersystemen mogelijk.
 - Te combineren met meerdere verpakkingsmachines.
- Eenvoudige bediening middels touchscreen.

DE

- Waage mit 12 Wiege behälter in 2 reihen von 6 gegenüberliegend.
- Optimal für hohe Kapazität bei kleine Packung.
- Verschiedene Abtransportsysteme möglich.
- Zu kombinieren mit verschiedenen Verpackungsmaschinen.
- Einfache Bedienung mittels Touchscreen.

EN

- Weigher with 12 weighing buckets in 2 rows of 6 opposite of each other.
- Optimised for high capacity runs with small weights.
- Various discharge systems possible.
- Combinations with many packaging machines possible.
- User-friendly touchscreen.



MD12

Weighing machine

NL Specificaties:	DE Spezifikationen:	EN Specifications:	
Weegbereik:	Wiegebereich:	Weighing range:	0.25 - 15 kg*
Capaciteit bij 2.5kg tot:	Leistung bei 2.5 kg bis zu:	Capacity at 2.5 kg up to:	54 drops/min*
Inhoud weegbak:	Inhalt vom Behälter:	Capacity of the bucket:	6 ltr
IP-beschermingsklasse	IP-Schutzklasse	IP-rating	IP54
Lucht consumptie: (geconditioneerde droge lucht)	Luftverbrauch: (konditionierte trockene Luft)	Air consumption: (conditioned dry air)	150 L/min
Voedingsspanning:	Spannungsdaten:	Supply voltage	3x 400V/50Hz+N+GND
Stroomverbruik:	Anschlusswert:	Powerconsumption:	5.1 kW
Gewicht van de machine:	Gewicht der Maschine:	Weight of the machine:	2050 kg

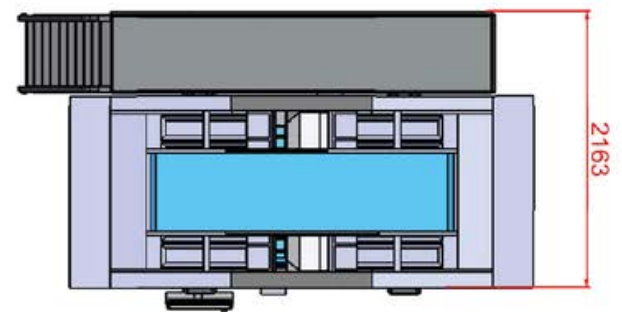
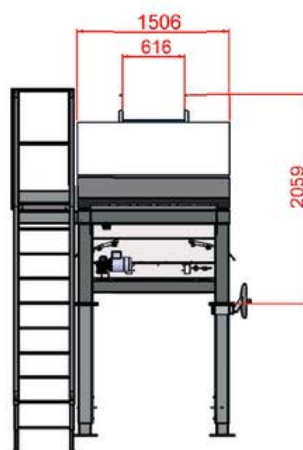
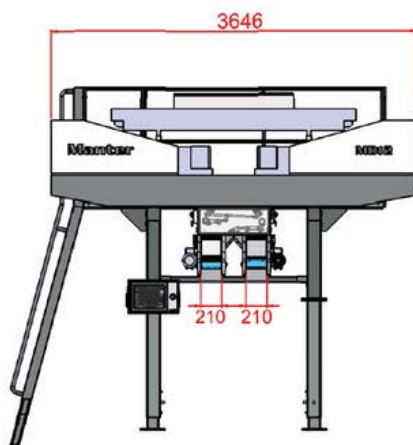

*Afhankelijk van product en afvoersysteem.
Abhängig von Produkt und Entladesystem.
Depends on product and discharge system.

Manter International B.V.

P.O. Box 2124 NL
7801 CC Emmen
The Netherlands

Office

Phileas Foggstraat
66 7825 AL Emmen
The Netherlands

Contact

+31 591 626300
sales@manter.com
www.manter.com

