



MD16

Weighing machine



NL

- Weger uitgevoerd met 16 weegschalen in 2 rijen van 8 tegenover elkaar.
- Optimaal voor kleine gewichten op een hoge snelheid.
- Verschillende afvoersystemen mogelijk.
- Te combineren met allerlei soorten verpakkingsmachines.
- Eenvoudige bediening middels touchscreen.

DE

- Waage aus Edelstahl mit 16 Wiegebehälter in 2 Reihe von 8 einander gegenüberliegende.
- Optimal für hohe Kapazität bei kleine Gewichte.
- Verschiedene Abtransportsysteme möglich.
- Zu kombinieren mit
- verschiedenen Verpackungsmaschinen.
- Einfache Bedienung mittels Touchscreen.

EN

- Weigher equipped with 16 weighing buckets in 2 rows of 8 opposite each other.
- Optimized for high capacity runs with small weights.
- Various discharge systems possible.
- Combinations with many packaging machines possible.
- User-friendly touchscreen.

MD16

Weighing machine

NL Specificaties:	DE Spezifikationen:	EN Specifications:	
Weegbereik:	Wiegebereich:	Weighing range:	0.5 - 10 kg*
Capaciteit bij 2.5kg tot:	Leistung bei 2.5 kg bis zu:	Capacity at 2.5 kg up to:	70 drops/min*
Inhoud weegbak:	Inhalt vom Behälter:	Capacity of the bucket:	6 ltr
IP-beschermingsklasse	IP-Schutzklasse	IP-rating	IP54
Lucht consumptie: (geconditioneerde droge lucht)	Luftverbrauch: (konditionierte trockene Luft)	Air consumption: (conditioned dry air)	150 L/min
Voedingsspanning:	Spannungsdaten:	Supply voltage	3x 400V/50Hz+N+GND
Stroomverbruik:	Anschlusswert:	Powerconsumption:	5.5 kW
Gewicht van de machine:	Gewicht der Maschine:	Weight of the machine:	2450 kg

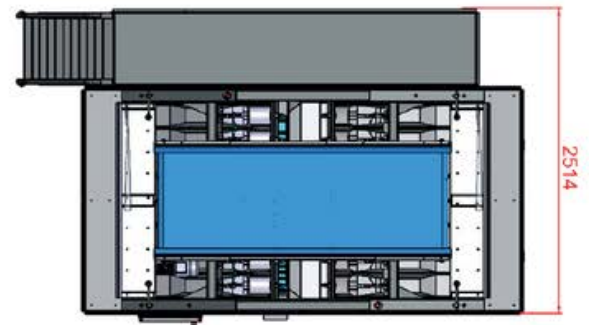
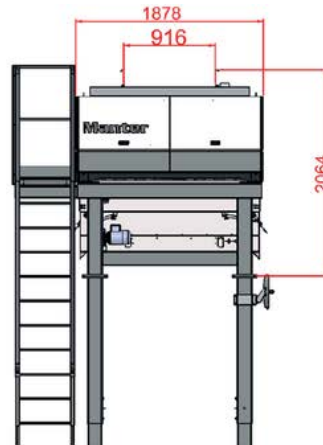
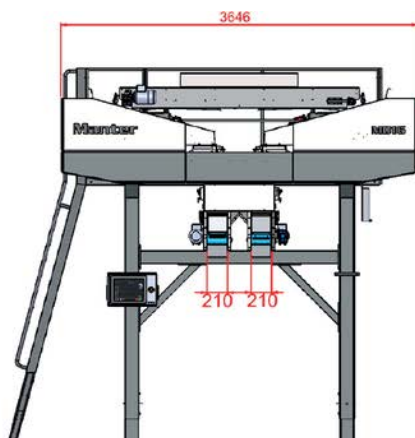

*Afhankelijk van product en afvoersysteem.
Abhängig von Produkt und Entladesystem.
Depends on product and discharge system.

Manter International B.V.

P.O. Box 2124 NL
7801 CC Emmen
The Netherlands

Office

Phileas Foggstraat
66 7825 AL Emmen
The Netherlands

Contact

+31 591 626300
sales@manter.com
www.manter.com

