

SemiPack+

Packaging machine



NL

- Halfautomatische verpakkingsmachine, voor enkelvoudige net-, jute- en papieren zakken.
- Intuïtief bedieningspaneel.
- Hoogste snelheid op de markt.
- Uitstekende connectiviteit voor service en communicatie met ERP/ MES systemen.
- Mooiste afwerking van zakken.
- Beste toegankelijkheid voor service en onderhoud.

DE

- Halbautomatische Verpackungsmaschine für einzelne Netz-, Jute- und Papiersäcke.
- Intuitives Bedienfeld.
- Höchste Geschwindigkeit auf dem Markt.
- Hervorragende Konnektivität für Service und Kommunikation mit ERP/MES-Systemen.
- Schönste Verarbeitung der Beutel.
- Beste Zugänglichkeit für Service und Wartung.

EN

- Semi-automatic packaging machine, for single net, jute and paper bags.
- Intuitive control panel.
- Highest speed in the market.
- Excellent connectivity for service and communication to ERP/ MES systems.
- Nicest finish of bags.
- Best accessibility for service and maintenance.

SemiPack+

Packaging machine

NL Specificaties:	DE Spezifikationen:	EN Specifications:	
Verpakkingsbereik:	Verpackungsbereich:	Packing range:	10 - 50 kg* (optional 5-50kg)
Zakbreedte	Breite des Beutels:	Bag width:	450 - 600 mm (5kg option: 315 - 380 mm) ¹
Zakhoogte	Höhe des Beutels:	Bag height:	560 - 1100 mm
Capaciteit bij 25kg tot:	Leistung bei 25kg bis zu:	Capacity at 25kg up to:	12 bags/min (manual)¹
IP-beschermingsklasse	IP-Schutzklasse	IP-rating	IP54
Lucht consumptie: (geconditioneerde droge lucht)	Luftverbrauch: (konditionierte trockene Luft)	Air consumption: (conditioned dry air)	50 L/min
Voedingsspanning:	Spannungsdaten:	Supply voltage	3x 400V/50Hz+N+GND²
Stroomverbruik:	Anschlusswert:	Powerconsumption:	5,5 kW
Gewicht van de machine:	Gewicht der Maschine:	Weight of the machine:	1300 kg

¹ Depending on the product, packaging material and chosen filling opening.

² 3x 220 Volt 60/Hz + GND optional

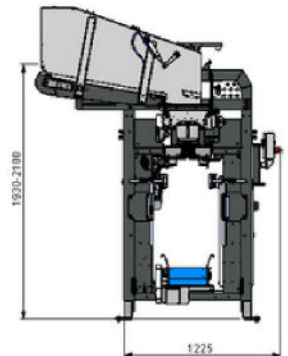
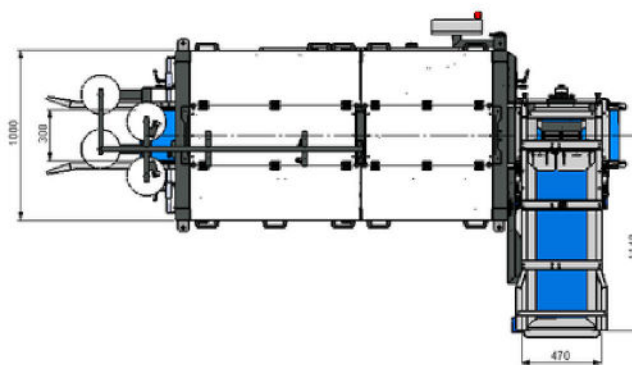
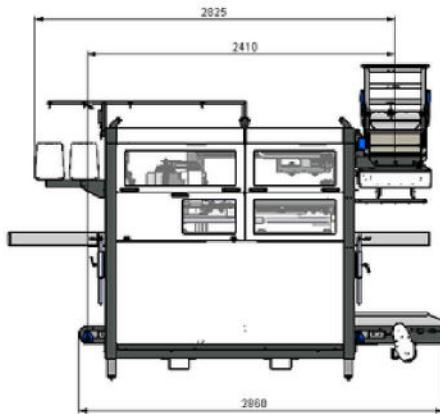

Manter International B.V.

P.O. Box 2124 NL
7801 CC Emmen
The Netherlands

Office

Phileas Foggestraat
66 7825 AL Emmen
The Netherlands

Contact

+31 591 626300
sales@manter.com
www.manter.com

